

Take Control.
ION
StormPro®



SHV40i+

Sewage Pump With Built-In High Water Alarm

- Light commercial sewage
- Residential sewage
- High-capacity sump
- Septic tank effluent



Patent No. 8,591,198



37 Forestwood Dr., Romeoville, IL 60446 www.ionproducts.net [815] 886-9200

SHV40i+

Sewage Pump With Built-In High Water Alarm

System Specifications

- Typical Applications
- Light commercial sewage
 - Residential sewage
 - High-capacity sump
 - Septic tank effluent

Maximum Capacity Up to 90 GPM

Maximum Head Up to 25'

Electrical Data 115 V, 1 ϕ , 8.5 FLA, 60 Hz

Motor Data 1/2 HP, 3450 RPM

Intermittent Liquid Temperature 130° F

Recommended Minimum Basin Size 18" x 30"

Automatic Operation i+: Ion+ (standard)

Materials of Construction Cast iron and stainless steel

Impeller Cast iron vortex

Power Cord 20' Standard

Discharge 2" NPT

Solids Handling 2"

Pump Dimensions

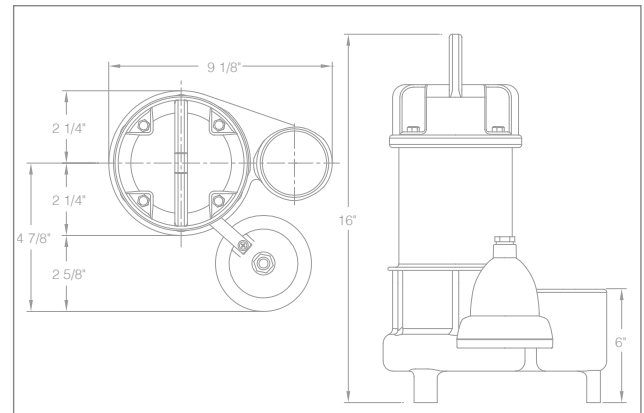

Pump Performance

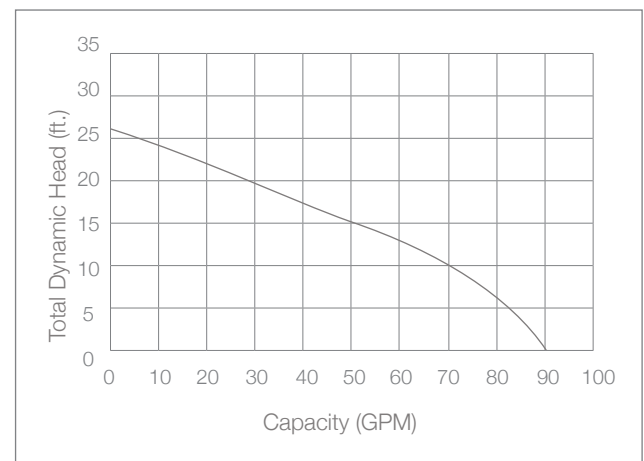

Features

- Carbon ceramic mechanical seal
- Automatic reset thermal overload for maximum protection
- Lower single-row ball-bearing construction
- Piggyback Ion+[®] digital level control switch with alarm has no moving parts (standard)
- 3 year warranty