

Take Control.
ION
StormPro®



SHK50i

Sewage Pump

- Septic tank effluent
- High capacity sump
- Commercial sewage
- Residential sewage



37 Forestwood Dr., Romeoville, IL 60446 www.ionproducts.net [815] 886-9200

Patent No. 8,591,198

SHK50i

Sewage Pump

System Specifications

Typical Applications	<ul style="list-style-type: none">• Septic tank effluent• High capacity sump• Commercial sewage• Residential sewage
Maximum Capacity	Up to 112 GPM
Maximum Head	Up to 24'
Electrical Data	<ul style="list-style-type: none">• 115 V, 1 Ø, 12.0 FLA, 60 Hz• 230 V, 1 Ø, 6.0 FLA, 60 Hz
Motor Data	½ HP, 1750 RPM
Intermittent Liquid Temperature	130° F
Recommended Minimum Basin Size	18" x 30"
Automatic Operation	i: Ion Digital Level Control (standard)
Manual Operation	M: Manual
Materials of Construction	Cast iron
Impeller	Cast iron non-clog
Power Cord	10' Standard (20' optional)
Discharge	2" NPT (3" optional)
Solids Handling	2"

Pump Dimensions

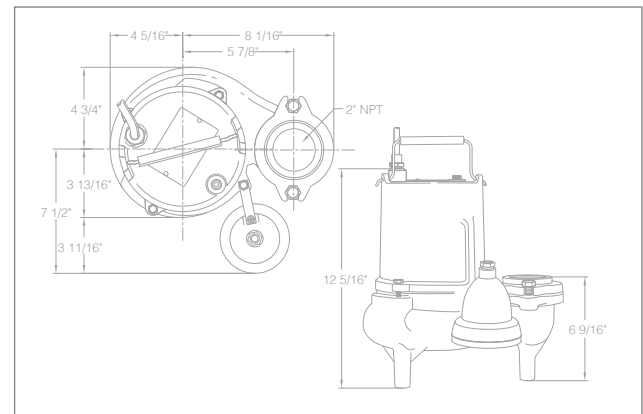

Pump Performance

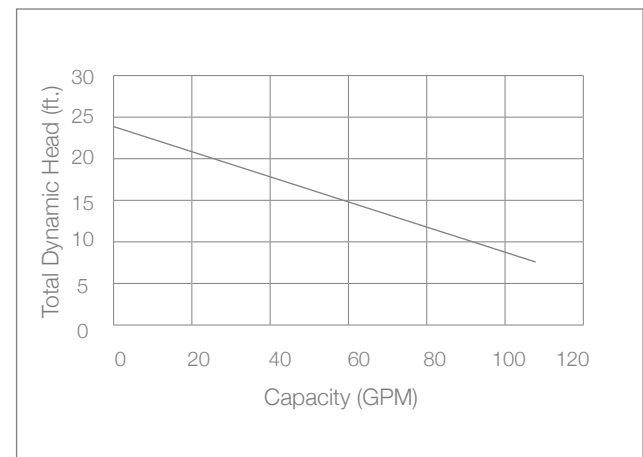

Features

- Carbon ceramic mechanical seal
- Automatic reset thermal overload for maximum protection
- Lower single-row ball-bearing construction
- Piggy back Ion® digital level control switch has no moving parts (standard)
- 3 year warranty