

Take Control.
ION
Technologies



SH50i

Sump Pump

- Basement Sump
- Septic Tank Effluent
- Dewatering



37 Forestwood Dr., Romeoville, IL 60446 www.ionproducts.net [815] 886-9200

Patent No. 8,591,198

SH50i

Sump Pump

System Specifications

Typical Applications	<ul style="list-style-type: none">• Basement sump• Dewatering• Septic tank effluent
Maximum Capacity	Up to 74 GPM
Maximum Head	Up to 33'
Electrical Data	115 V, 1 Ø, 8.5 FLA, 60 Hz
Motor Data	1/2 HP, 3450 RPM
Recommended Minimum Basin Size	18" x 24"
Automatic Operation	i: Ion Digital Level Control (standard) W: Wide angle float V: Vertical float
Manual Operation	M: Manual
Materials of Construction	Cast iron
Impeller	Non-clog vortex
Power Cord	20' Standard
Discharge Size	2" NPT
Solids Handling	3/4"

Pump Dimensions

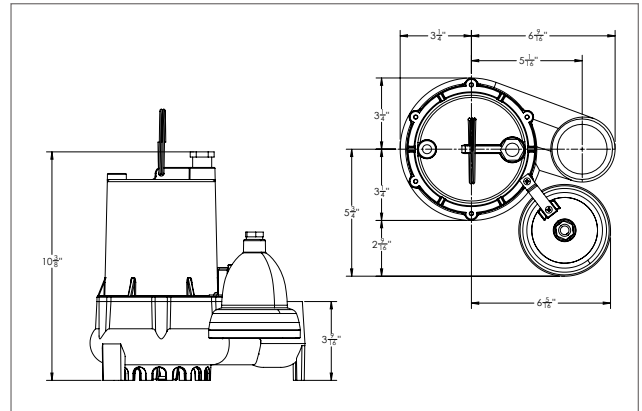

Pump Performance

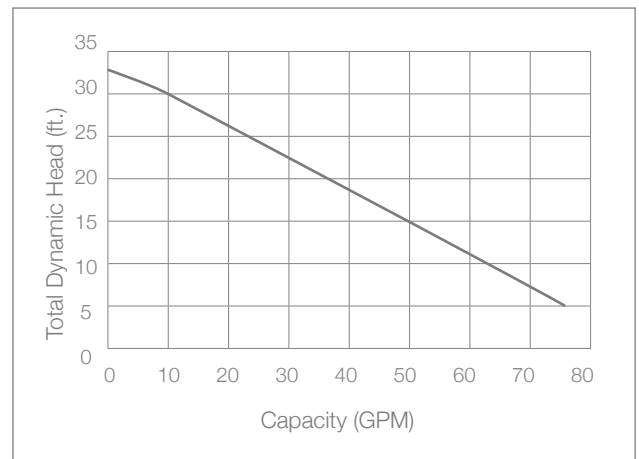

Features

- Carbon ceramic mechanical seal
- Oil-filled motor with automatic reset thermal overload
- Uses single-row ball bearing construction
- Piggy back Ion® digital level control switch has no moving parts (standard)
- 3 year warranty