

Take Control.
ION
Technologies

A division of Metropolitan Industries, Inc.



HT40

1 YEAR
WARRANTY



Submersible Sump Pump

- Boiler blow down
- Condensate pits
- Hot water transfer



37 Forestwood Dr., Romeoville, IL 60446
www.ionproducts.net [815] 886-9200

HT40

Submersible Sump Pump

System Specifications

Typical Applications	<ul style="list-style-type: none">• Boiler blow down• Condensate pits• Hot water transfer
Maximum Capacity	Up to 50 GPM
Maximum Head	Up to 23'
Electrical Data	115 V, 1 \emptyset , 12 FLA, 60 Hz
Motor Data	1/3 HP, 1750 RPM
Intermittent Liquid Temperature	194° F
Recommended Minimum Basin Size	18" x 24"
Manual Operation	M: Manual (standard)
Automatic Operation	High temperature float
Materials of Construction	Cast iron
Impeller	Thermoplastic vortex
Power Cord	20' Standard
Discharge	1 1/2" NPT
Solids Handling	3/4"

Pump Dimensions

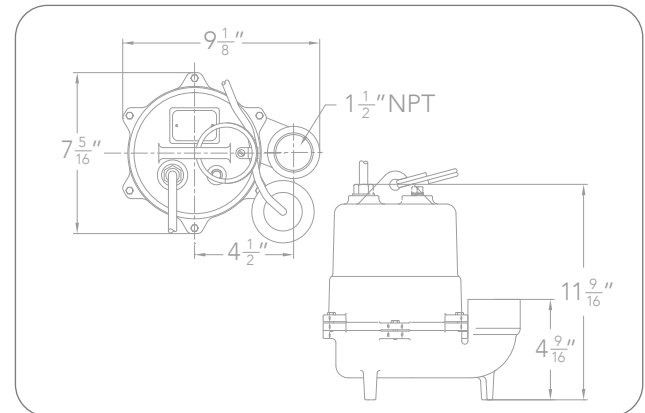

Pump Performance

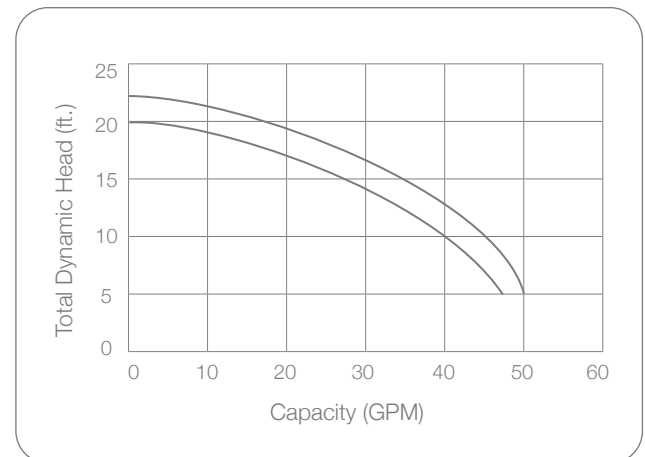

Features

- Carbon ceramic mechanical seal
- Automatic reset thermal overload for maximum protection
- Piggy back models available
- 1 year warranty